



# Torque Motors

## Additional Information

- Technical Reference .....F-1
- General Information .....G-1

# Torque Motors

Torque motors are designed to provide high starting torque and sloping characteristics (torque is highest at zero speed and decreases steadily with increasing speed), and operate over a wide speed range. They also provide stable operation, especially in the low speed range or under a locked rotor condition.

## Features

### Speed can be varied over a wide range

The motor torque is approximately proportional to the square of the voltage, allowing easy speed control simply by changing the voltage of the power supply.

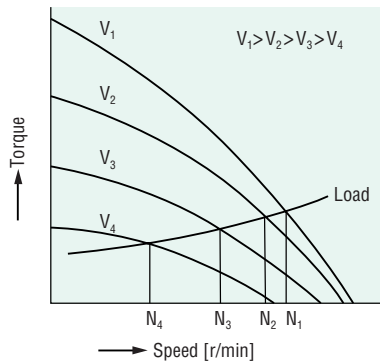

### Suitable for winding applications

In an application where an object is released continuously at a constant speed and wound up with constant tension, the torque must be doubled and the speed must be halved if the diameter of the winding spool is doubled.

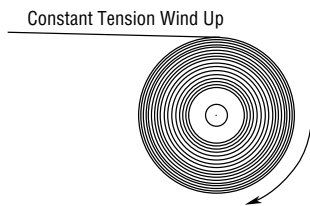

### Locked rotor operation is available

Unlike induction motors or reversible motors, torque motors are designed to provide a stable torque even under stall conditions or at very low speeds (nearly stalling). They are suitable for pushing applications that require static torque, or for loads that are usually under a locked rotor condition but are under stall conditions at the end of processes. The motors can operate continuously at 60 VAC or less. When used at voltages above 60 VAC, the motors are rated for limited duty. The motor has a 5-minute rating at 115 VAC.

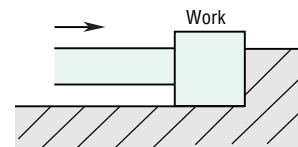

#### Note:

- When using a motor in a locked rotor condition, the output torque becomes very large. Do not exceed the permissible torque of the gearhead. Also, ensure that the work does not hit an object and stop, since this can cause damage to the gearhead due to the shock.

### Use as a brake

By using the motor in the braking region of the speed-torque characteristics, it can serve as a brake. Constant tension operation can be achieved by applying a DC voltage.

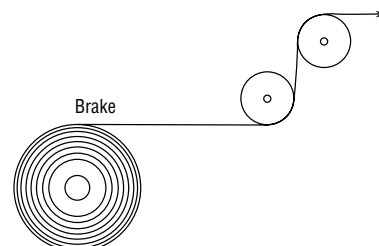

## System Configuration

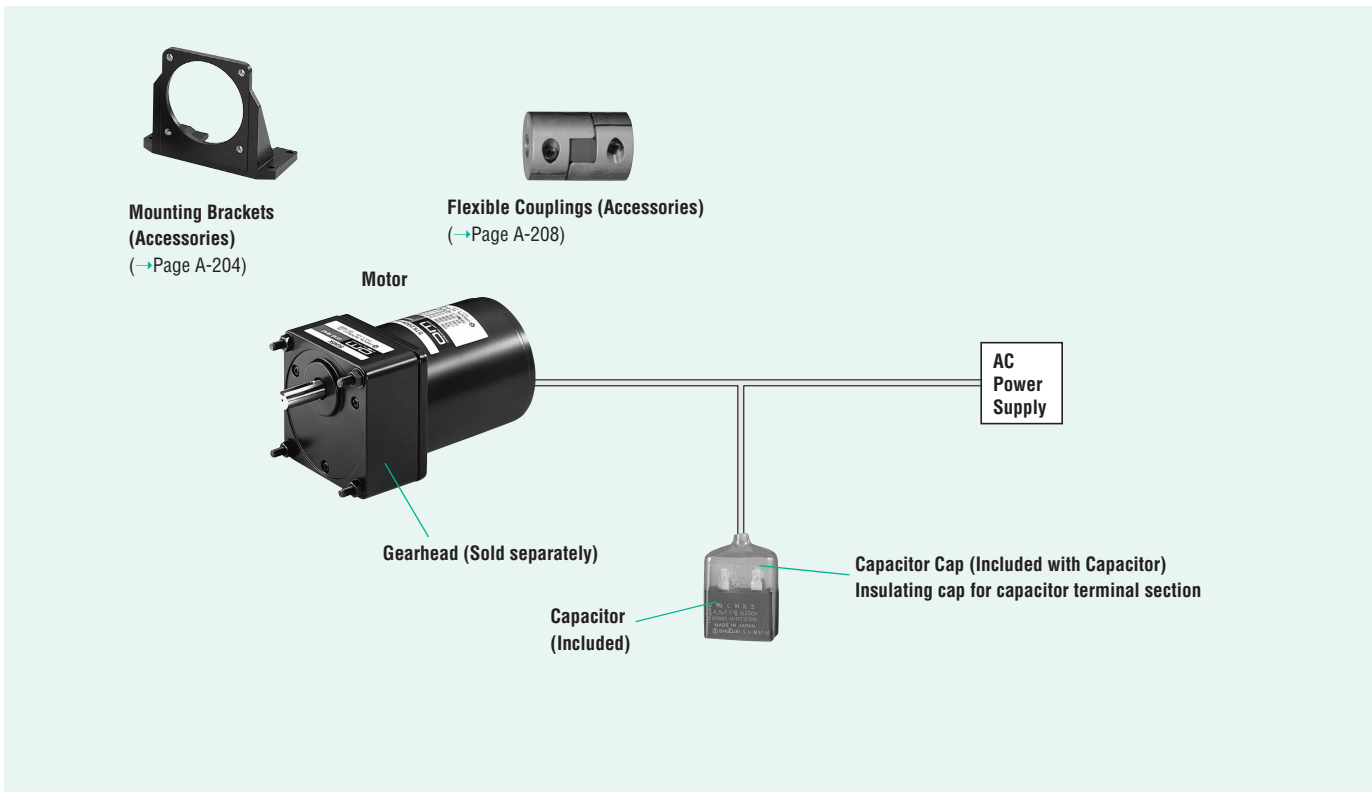

The system configuration shown above is an example. Other configurations are available.

## Product Number Code

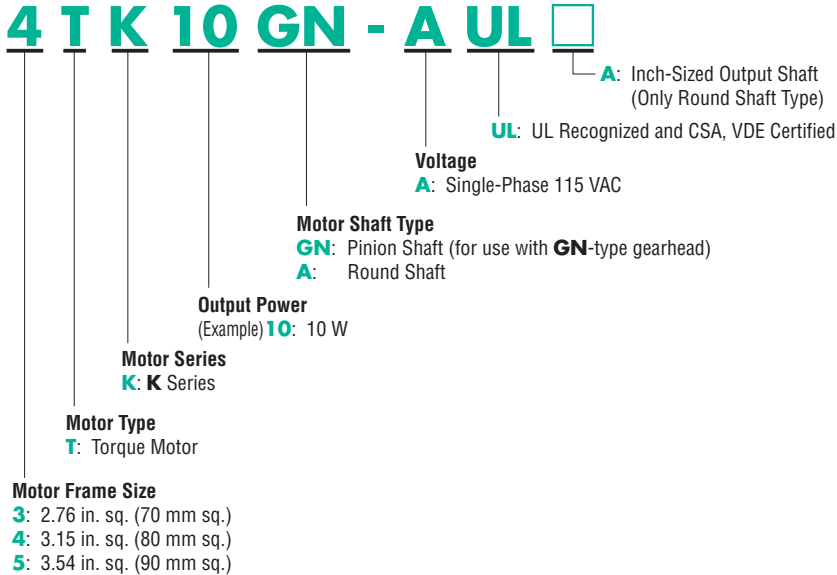

• Gearhead Product Number Code →Page A-16

## Safety Standards and CE Marking

Standards	Certification Body	Standards File No.	CE Marking
UL1004 UL547	UL	E64197	Low Voltage Directives
CSA C22.2 No.100 CSA C22.2 No.77	CSA	LR47296	
EN60950	VDE	5877ÜG	

• Details of Safety Standards →Page G-2

## How to Read Speed–Torque Characteristics Graph

The torque generated by the torque motor changes approximately proportionally to the square of the voltage. When the voltage supplied to the motor is changed, speed-torque curves with a sloping characteristics (torque is highest at zero speed and decreases steadily with increasing speed) shifts to that of the corresponding voltage.

When the voltage is changed to 115 VAC, 80 VAC and 60 VAC while the load torque is  $T_0$ , the motor rotates at the speeds  $N_1$ ,  $N_2$  and  $N_3$  respectively. Thus, the speed can be changed easily by varying the voltage.

When choosing a torque motor, first determine the required torque and speed. Then select a motor using the speed-torque characteristics curves to determine whether the motor should be operated under continuous duty or limited duty.

When used under locked rotor conditions, only the torque factor is considered.

The temperature rise of the motor may cause a problem during continuous operation. In this case, choose a motor with an output power large enough for continuous operation and adjust the voltage to control the torque and speed.

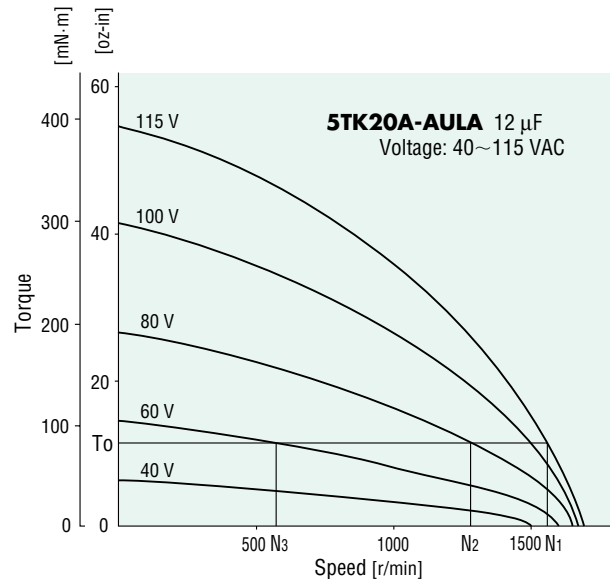

## Voltage Control of Torque Motors

The method most commonly used to control voltage is by phase control using a triac. As shown in the figure to the right, by changing the phase angle “alpha” at which the triac switches, the input voltage is controlled as represented by the phase angle areas of the graph.

- When adjusting the speed or the torque, an external voltage adjuster is necessary.

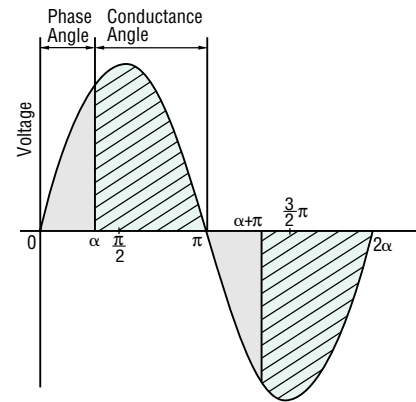

Phase Control

## Specifications



Model		Rating at Locked Rotor	Voltage VAC	Frequency Hz	Starting Torque oz-in	Output Power	At max. output power					Capacitor μF		
Pinion Shaft Type	Round Shaft Type						Speed r/min	Torque oz-in	Torque mN·m	Current A	Input W			
ⓉP	<b>3TK6GN-AUL</b> <b>3TK6A-AULA</b>	5 minutes Continuous	Single-phase 115 Single-phase 60	60	21 6.3	150 45	1/93 1/300	8 2.5	900	12.3 3.8	87 27	0.62 0.34	67 20	8.0
ⓉP	<b>4TK10GN-AUL</b> <b>4TK10A-AULA</b>	5 minutes Continuous	Single-phase 115 Single-phase 60	60	27 7.1	195 50	1/62 1/270	12 2.8	900	18.4 4.4	130 31	0.66 0.32	70 19	8.0
ⓉP	<b>5TK20GN-AUL</b> <b>5TK20A-AULA</b>	5 minutes Continuous	Single-phase 115 Single-phase 60	60	49 12.7	350 90	1/32 1/125	23 6	900	35 9.2	250 65	1.0 0.49	110 29	12.0

ⓉP Contains a built-in thermal protector. If a motor overheats for any reason, the thermal protector is opened and the motor stops. When the motor temperature drops, the thermal protector closes and the motor restarts. Be sure to turn the motor off before inspecting.

## General Specifications

Item	Specifications
Insulation Resistance	100 MΩ or more when 500 VDC is applied between the windings and the frame after rated motor operation under normal ambient temperature and humidity.
Dielectric Strength	Sufficient to withstand 1.5 kV at 60 Hz applied between the windings and the frame for 1 minute after rated motor operation under normal ambient temperature and humidity.
Temperature Rise	135°F (75°C) or less measured by the resistance change method after rated motor operation.
Insulation Class	UL/CSA Standard Class A [221°F (105°C)], EN Standard Class E [248°F (120°C)].
Overheat Protection	Built-in thermal protector (Automatic return type) Operating temperature, open: 248°F±9°F (120°C±5°C) close: 170.6°F±27°F (77°C±15°C)
Ambient Temperature Range	14°F~104°F (-10°C~+40°C)(nonfreezing)
Ambient Humidity	85% maximum (noncondensing)
Degree of Protection	IP20

## Gearheads (Sold Separately)

### Parallel Shaft

Model	Gear Ratio
<b>3GN□KA</b>	<b>3~180</b>
<b>3GN10XK</b> (Decimal Gearhead)	
<b>4GN□KA</b>	<b>3~180</b>
<b>4GN10XK</b> (Decimal Gearhead)	
<b>5GN□KA</b>	<b>3~180</b>
<b>5GN10XK</b> (Decimal Gearhead)	

- Enter the gear ratio in the box (□) within the model name.

## Gearmotor–Torque Table

The permissible torque when a gearhead and a decimal gearhead are directly connected can be calculated according to the following formula, using the speed and torque determined from the speed-torque characteristics.

$$\text{Speed of gearhead output shaft } N_G = \text{Motor speed} \times 1/\text{gearhead gear ratio}$$

$$\text{Output torque of gearhead } T_G = \text{Motor torque} \times \text{Gearhead gear ratio} \times \text{Gearhead efficiency}$$

The output torque of the gearhead must be lower than the maximum permissible torque.

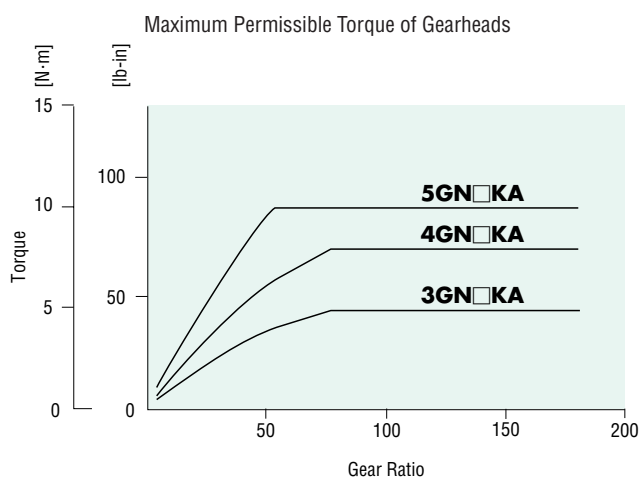

Gearhead Model	Gearhead Gear Ratio	Gearhead Efficiency
<b>3GN□KA</b>	<b>3, 3.6, 5, 6, 7.5, 9, 12.5, 15, 18</b>	81%
<b>4GN□KA</b>	<b>25, 30, 36</b>	73%
<b>5GN□KA</b>	<b>50, 60, 75, 90, 100, 120, 150, 180</b>	66%

- Gearheads and decimal gearheads are sold separately.
- Enter the gear ratio in the box (□) within the model name.

## Speed – Torque Characteristics (Reference Values)

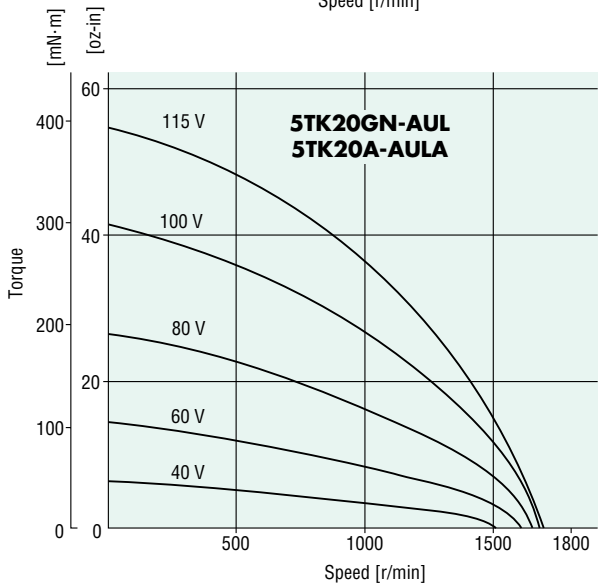
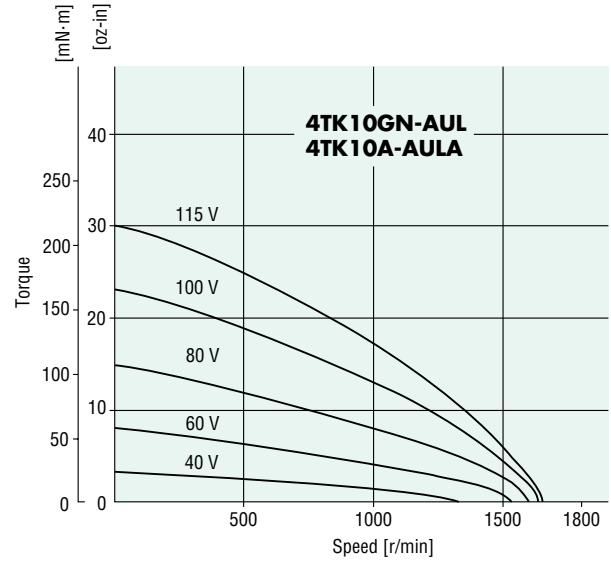
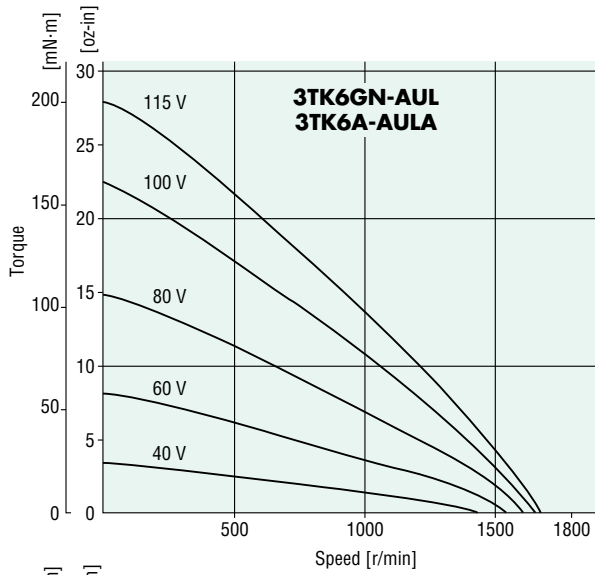

## Dimensions Scale 1/4, Unit = inch (mm)

- **Motor**
- **3TK6GN-AUL** Weight: 2.4 lb. (1.1 kg)
- **3TK6A-AULA** Weight: 1.2 lb. (0.55 kg)
- **DXF A010AU (3GN3KA~18KA)**
- **A010BU (3GN25KA~180KA)**

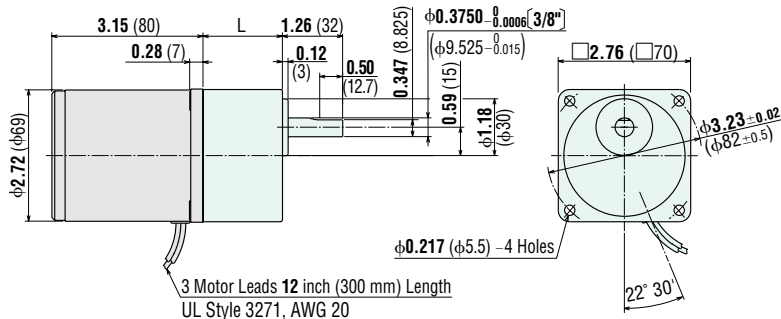

**3GN3KA~18KA:** L = 1.26 (32)  
**3GN25KA~180KA:** L = 1.65 (42)

● Round Shaft Type

**3TK6A-AULA**

Weight: 2.4 lb. (1.1 kg)

**DXF** A326U

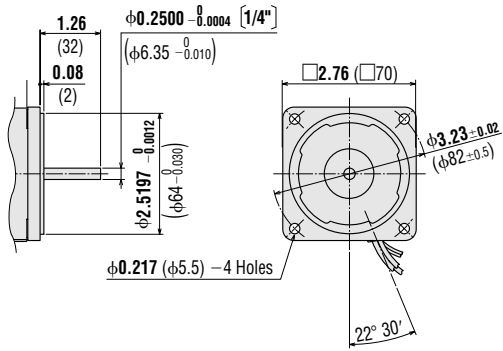

● Decimal Gearhead

(For **3TK6GN-AUL**)

**3GN10XK**

Weight: 0.66 lb. (0.3 kg)

**DXF** A009

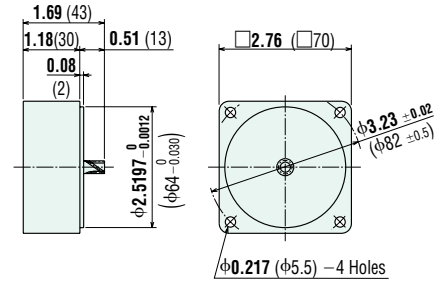

● Motor

**4TK10GN-AUL**

Weight: 3.3 lb. (1.5 kg)

**DXF** A014AU (**4GN3KA~18KA**)

A014BU (**4GN25KA~180KA**)

Gearhead

**4GN□KA**

Weight: 1.4 lb. (0.65 kg)

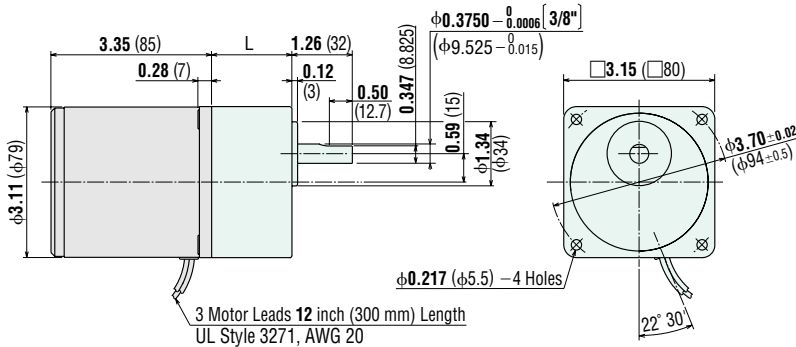

**4GN3KA~18KA:** L = 1.26 (32)  
**4GN25KA~180KA:** L = 1.67 (42.5)

● Round Shaft Type

**4TK10A-AULA**

Weight: 3.3 lb. (1.5 kg)

**DXF** A327U

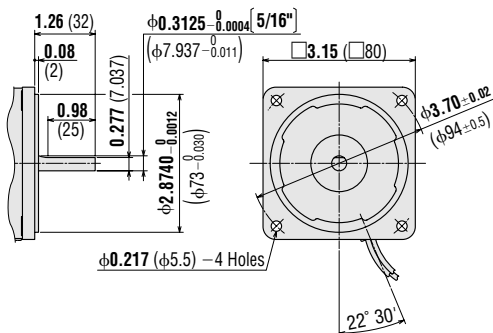

● Decimal Gearhead

(For **4TK10GN-AUL**)

**4GN10XK**

Weight: 0.88 lb. (0.4 kg)

**DXF** A013

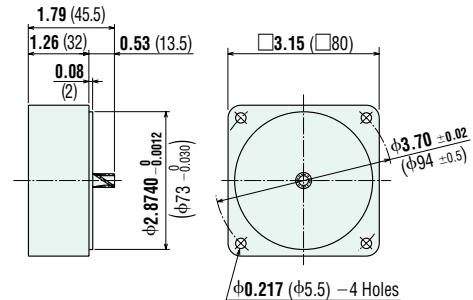

Introduction  
 Induction Motors  
 Reversible Motors  
 Synchronous Motors  
 Torque Motors  
 Watertight Motors  
 Magnetic Brake  
 Clutch & Brake  
 Brake Pack  
 Right-Angle Gearheads  
 Accessories  
 Before Using a Standard AC Motor

- **Motor**  
**5TK20GN-AUL**  
Weight: 5.5 lb. (2.5 kg)
- **Gearhead**  
**5GN□KA**  
Weight: 3.3 lb. (1.5 kg)
- **DXF** A019AU (**5GN3KA~18KA**)  
A019BU (**5GN25KA~180KA**)

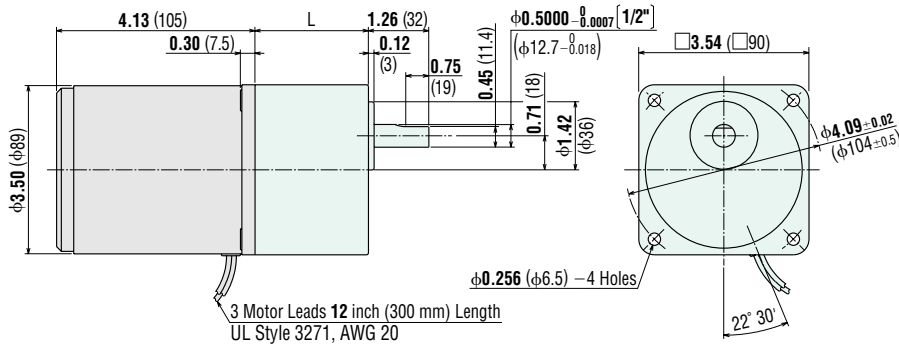

**5GN3KA~18KA:** L = 1.65 (42)  
**5GN25KA~180KA:** L = 2.36 (60)

- **Round Shaft Type**  
**5TK20A-AULA**

Weight: 5.5 lb. (2.5 kg)  
● **DXF** A329U

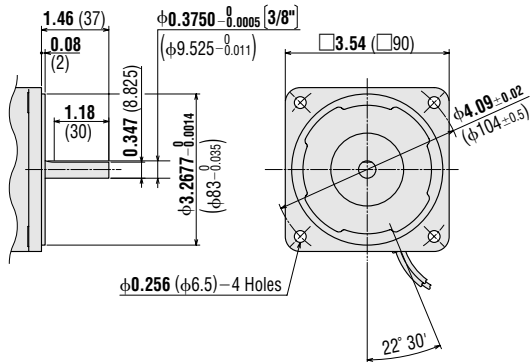

- **Decimal Gearhead**  
(For **5TK20GN-AUL**)

**5GN10XK**  
Weight: 1.3 lb. (0.6 kg)  
● **DXF** A022

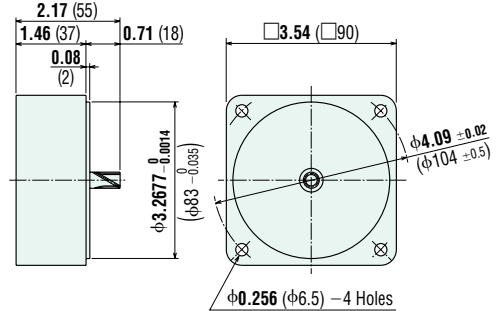

- **Capacitor** (included with the motors)

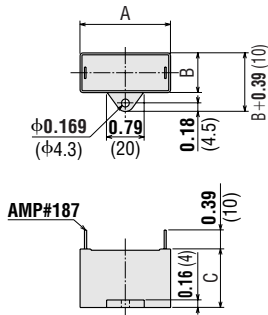

Motor Model	Capacitor Model	Dimensions in. (mm)			Weight oz. (g)
		A	B	C	
<b>3TK6GN-AUL</b>	CH80UL	1.50	0.83	1.22	1.2 (35)
<b>3TK6A-AULA</b>		(38)	(21)	(31)	
<b>4TK10GN-AUL</b>	CH80UL	1.50	0.83	1.22	1.2 (35)
<b>4TK10A-AULA</b>		(38)	(21)	(31)	
<b>5TK20GN-AUL</b>	CH120CUL	2.28	0.83	1.22	1.8 (50)
<b>5TK20A-AULA</b>		(58)	(21)	(31)	

• If you need to order a capacitor with out a motor, add “-C” to the capacitor model name shown. A capacitor cap is included with the capacitor.

## Connection Diagram

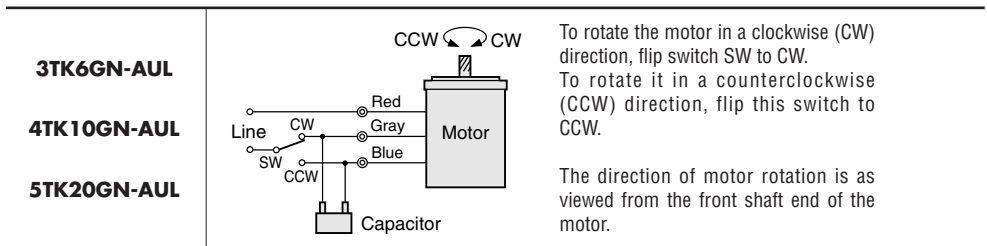

- The direction of motor rotation is as viewed from the shaft end of the motor.
- CW represents the clockwise direction, while CCW represents the counterclockwise direction.
- Connection diagrams are also valid for the equivalent round shaft motors.
- **How to connect a capacitor** → Page A-225